

## 5" TACHOMETER

## INSTALLATION INSTRUCTIONS

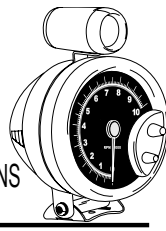

## GENERAL INFORMATION

Please read this instruction manual and review the installation procedures carefully before attempting the installation of your tachometer.

## CAUTION

This unit is designed for use on 12-volt negative (-) ground 4-cycle automotive type engines. The tachometer is compatible with most distributor and distributorless ignition systems.

## PACKAGE CONTENTS

Contains Installation Hardware Kit consisting of:

Tachometer Mounting Base Pad.....	1 ea
1/4" Quick Connect Receptacle.....	1 ea
Grommet.....	1 ea
Hex Key Wrench.....	1 ea
Wire Splices.....	2 ea
Ring Terminals.....	2 ea
#10 X 5/8" Self-tapping Screw.....	2 ea

## SAFETY GUIDELINES

To prevent accidents that could result in serious injury and/or damage to your vehicle or tachometer, carefully follow these safety rules and test procedures.

## Fire Extinguisher

Never work on your vehicle without having a suitable fire extinguisher handy. A 5-lb or larger CO<sub>2</sub> or dry chemical unit specified for gasoline/chemical/electrical fires is recommended.

## Safety Goggles

We recommend wearing safety goggles when working on your vehicle, to protect your eyes from battery acid, gasoline, and dust and dirt flying off moving engine parts.

Be very careful not to get your hands, hair or clothes near any moving parts such as fan blades, belts and pulleys or throttle and transmission linkages. Never wear neckties or loose clothing when working on your vehicle.

Never wear wrist watches, rings or other jewelry when working on your vehicle. You'll avoid the possibility of catching on moving parts or causing an electrical short circuit which could shock or burn you.

The carbon monoxide in exhaust gas is highly toxic. To avoid asphyxiation, always operate vehicle in a well-ventilated area. If vehicle is in an enclosed area, exhaust should be routed directly to the outside via leakproof exhaust hose.

Make sure that your vehicle is in Park or Neutral, and that the parking brake is firmly set.

Avoid contact with hot surfaces such as exhaust manifolds and pipes, mufflers (catalytic converters), radiator and hoses.

Never smoke while working on your vehicle. Gasoline vapor is highly flammable, and the gas formed in a charging battery is explosive.

Do not lay tools or equipment on the battery. Accidentally grounding the "HOT" battery terminal can shock or burn you and damage wiring, the battery or your tools and testers. Be careful of contact with battery acid. It can burn holes in your clothing and burn your skin or eyes.

- High voltage — 30,000 to 50,000 volts — is present in the ignition coil, distributor cap, ignition wires and spark plugs. When handling ignition wires while the engine is running, use insulated pliers to avoid a shock. While not lethal, a shock may cause you to jerk involuntarily and hurt yourself.
- Never crawl under vehicle or run engine while vehicle is on a jack.

## CYLINDER SELECTION

Check the cylinder setting before installation. The Cylinder Selector Switch is located on the back of the tachometer, behind the door (see figure 1). The Factory Setting is 8 Cylinders. Change the setting if necessary.

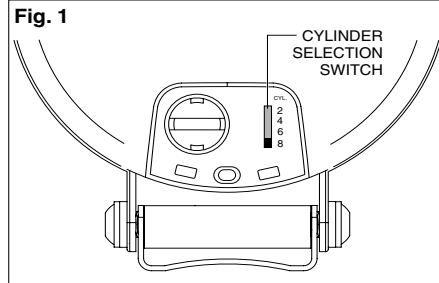

## DISTRIBUTOR EQUIPPED ENGINES

Set the switch to match the number of cylinders in the engine.

## DISTRIBUTORLESS IGNITION SYSTEM EQUIPPED ENGINES

The tachometer-ignition connection for some 4 Cylinder and 6 Cylinder DIS (Distributorless Ignition System) engines requires that you use the 2 Cylinder setting. Depending on which type of system you have, set the switch as follows:

If your vehicle's DIS ignition system has a tachometer output lead set the switch to the 4 Cylinder position for the 4 cylinder engines and to the 6 Cylinder position for the 6 cylinder engines. When connecting tachometer wires (see **ELECTRICAL CONNECTIONS**), connect the tachometer **GREEN** wire to the vehicle's tachometer output lead.

If your vehicle's DIS ignition system does not have a tachometer output lead but allows access to the driver wires from the vehicle computer to the ignition module, set the switch to the 2 Cylinder position regardless of the number of cylinders in the engine. When connecting tachometer wires (see **ELECTRICAL CONNECTIONS**), connect the tachometer **GREEN** wire to either of the driver wires.

## FUNCTIONAL QUICK CHECK

It is suggested that the tachometer be electrically connected to the vehicle, (using alligator clip leads or other suitable means) following the steps below, and an electrical functional check of the tachometer be made, prior to making a permanent installation.

Start the vehicle's engine. Confirm the operation of the tachometer. Disconnect tachometer.

## MOUNTING THE TACHOMETER

Your tachometer is designed to be mounted on any flat or curved surface, or on the steering column (see figure 2).

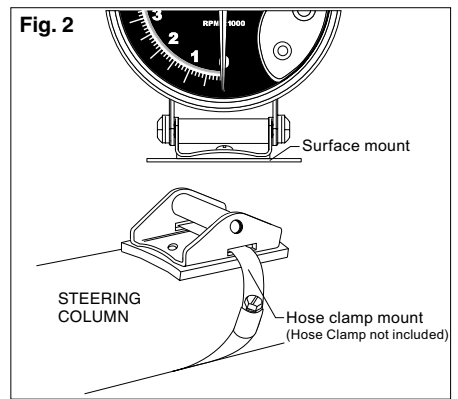

If #10 screws are used, mark hole locations, and drill holes using #18 or 11/64" drill bit.

- Loosen both button head screws on the mounting bracket. Now, tachometer can tilt back and forth (see figure 3).
- Install #10 screws (see figure 3).
- Slide the Shift Light around the tachometer to desired position (see figure 4).
- Tighten both button head screws on the mounting bracket (see figure 4).

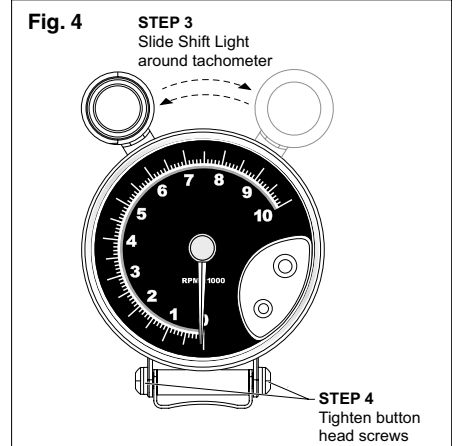
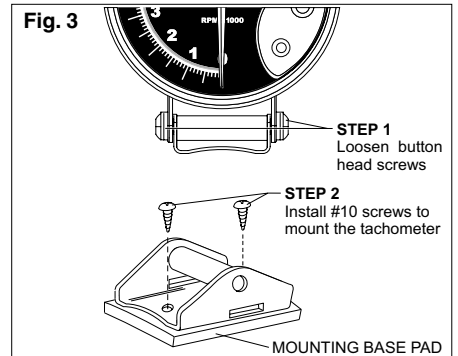

## ELECTRICAL CONNECTIONS

## CAUTION

For your own personal safety, and to prevent possible damage to the electrical system of your vehicle during the installation, disconnect the negative (-) battery cable. Reconnect this cable after installation is complete.

Do not route wires along or against sharp edges, hot engine surfaces, or near spark plug wires. If needed, drill a 3/8" hole for the grommet (included).

**NOTE:** If additional wire is needed, use #18 or #20 AWG stranded automotive primary wire.

## BLACK, RED, AND WHITE WIRE CONNECTIONS – ALL SYSTEMS

1. Connect the **BLACK** wire to the negative (-) battery terminal, or a clean unpainted chassis ground using a ring terminal or other suitable means (see figure 5.)  
Make the following connections with wire splices, or by an alternative method if desired (see figure 6.)
2. Connect the **RED** wire to any vehicle harness wire which is energized with battery voltage, **ONLY** when the ignition key is in the **ON (RUN)** position, **NOT OFF OR ACCESSORIES** (see figure 5.)
3. Connect the **WHITE** wire to the instrument panel lighting circuit that is controlled by the instrument panel dimmer control (see figure 5.)

Some vehicles (typically imported) wire the dimmer control into the ground side of the instrument panel lighting circuit, as opposed to the more conventional "hot" or 12-volt side. In vehicles which use this circuit, connect the **WHITE** wire to a circuit which is energized by the headlamp switch.

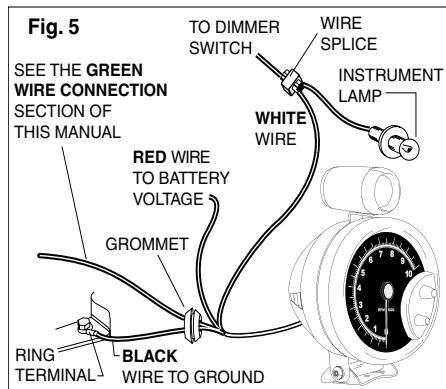

Fig. 5

SEE THE GREEN WIRE CONNECTION SECTION OF THIS MANUAL

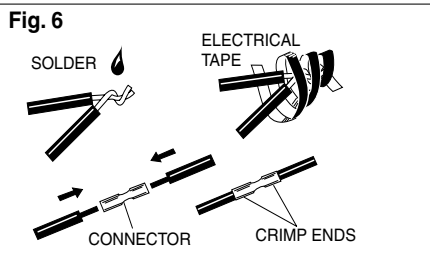
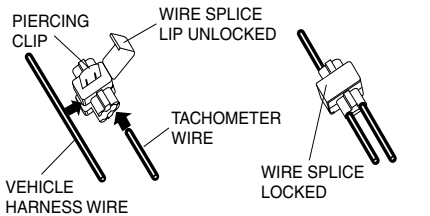

Fig. 6



## GREEN WIRE CONNECTION

The **GREEN** wire provides the tachometer with the engine RPM (speed) signal.

## DISTRIBUTOR EQUIPPED ENGINES

Connect the **GREEN** wire to the negative (-) side of the ignition coil. This terminal may also be referred to as the TACH, TACH TEST, DEC, or ECU terminal.

## DISTRIBUTORLESS IGNITION SYSTEM EQUIPPED ENGINES

If your vehicle's DIS ignition system has a tachometer output lead set the switch to the 4 Cylinder position for the 4 cylinder engines and to the 6 Cylinder position for the 6 cylinder engines. Connect the tachometer **GREEN** wire to the vehicle's tachometer output lead.

If your vehicle's DIS ignition system does not have a tachometer output lead but allows access to the driver wires from the vehicle computer to the ignition module, set the switch to the 2 Cylinder position regardless of the number of cylinders in the engine. Connect the tachometer **GREEN** wire to either of the driver wires.

## MULTIPLE SPARK DISCHARGE IGNITION SYSTEM EQUIPPED ENGINES

For Multiple Spark Discharge ignition systems, connect the **GREEN** wire only to the tachometer output terminal on the ignition module. **Do NOT** connect to the ignition coil.

## SHIFT LIGHT RPM TRIP POINT SET-UP

Some possible uses for the Shift Light are:

- Engine **RED LINE** (maximum safe operating speed of the engine)
- Engine maximum torque RPM (for maximum performance shifting) and desired shift speed.

**NOTE:** You will need both hands free to set the tachometer (see figures 7 and 8).

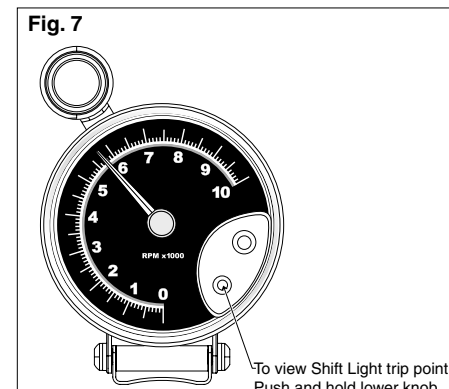

Fig. 7

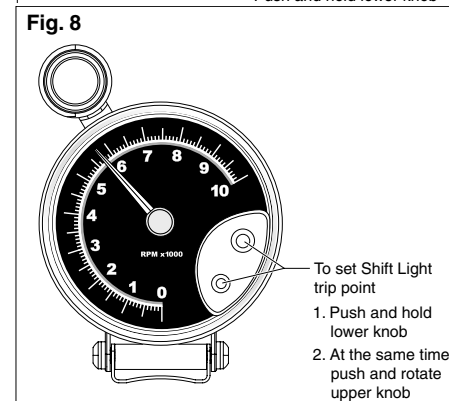

Fig. 8

1. Turn the ignition key to the **ON** position. The engine does not have to be running.
2. Push and keep the **LOWER** knob depressed.
3. Push in and rotate the **UPPER** control knob until the tachometer pointer indicates the RPM trip point at which the Shift Light should turn **ON**.
4. Release both the **LOWER** knob and the **UPPER** control knob.

**Note:** If at any time the tach pointer appears to freeze beyond the 10,000 RPM marker: 1) Turn on the ignition 2) Push and hold both knobs 3) Turn the **UPPER** knob fully clockwise and then return to the desired trip point.

## BACKLIGHTING LAMP SUBSTITUTION OR REPLACEMENT

The tachometer is supplied with a #168 wedge base lamp. If the light is too bright, replace with a lamp of less intensity such as a #194 or #161.

The lamp socket is located in the rear of the housing of the tachometer (see figure 9). To remove the lamp, gently grasp the black lamp socket (use pliers if necessary) and twist it counterclockwise approximately 1/8 turn until it stops. Pull the socket with lamp straight out of the tachometer housing. Remove the lamp from its socket by pulling it straight out. Replace the lamp. Reinstall the socketed lamp by rotating it against the tachometer's internal PC board until it drops into place, and then rotate it approximately 1/8 turn clockwise until it reaches its mechanical stop.

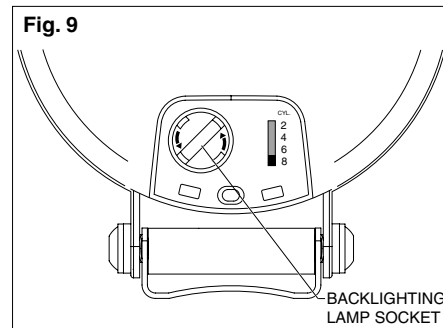

Fig. 9

## SHIFT LIGHT LAMP REPLACEMENT

The External Shift Light also uses a wedge base lamp for illumination.

To replace the Shift Light lamp, follow steps to open the shift light (see figure 10). Remove the lamp from its socket by pulling it straight out. Replace the lamp with a #168 automotive lamp. If light is too bright, replace with a lamp of less intensity such as #194 or #161. Reassemble the shift light by reversing the steps.

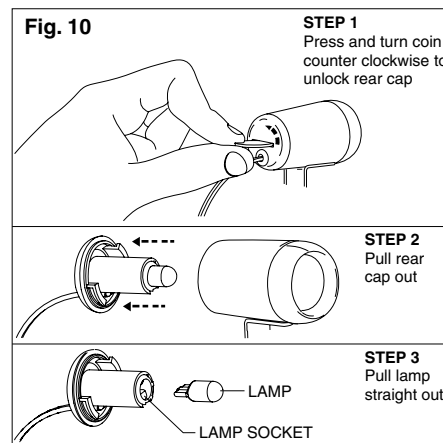

Fig. 10

**STEP 1**  
Press and turn coin counter clockwise to unlock rear cap

**STEP 2**  
Pull rear cap out

**STEP 3**  
Pull lamp straight out

## FULL ONE (1) YEAR WARRANTY

Bosch Automotive Service Solutions, 3000 Apollo Drive, Brook Park, Ohio 44142, warrants to the user that this unit will be free from defects in materials and workmanship for a period of one (1) year from the date of original purchase.

Any unit that fails within this period will be repaired or replaced at Bosch's option and without charge when returned to the factory. Bosch requests that a copy of the original, dated sales receipt be returned with the unit to determine if the warranty period is still in effect.

This warranty does not apply to damages caused by accident, alterations, or improper or unreasonable use. Expendable items, such as batteries, fuses, lamp bulbs, flash tubes are also excluded from this warranty.

BOSCHAUTOMOTIVESERVICE SOLUTIONS DISCLAIMS ANY LIABILITY FOR INCIDENTAL OR CONSEQUENTIAL DAMAGES FOR BREACH OF ANY WRITTEN WARRANTY ON THE UNIT. Some states do not allow the disclaimer of liability for incidental or consequential damages, so the above disclaimer may or may not apply to you. This warranty gives specific legal rights, and you may also have rights, which vary from state to state.